

RACE EVOLUTION  
 TEAM KIT 08  
 HT1 / HT2

DRIVER Hannes Käufler  
 DATE 26.07.08 TRACK Laupheim  
 EVENT 5. Round D-Cup 2008

**TUNING**

**WHEELS**

FRONT WHEELS TIRES SLD Performance RIMS Hörmann Softline INSERTS soft LENGTH 9 MM  
 REAR WHEELS TIRES SLD Performance RIMS Hörmann Softline INSERTS soft LENGTH 5 MM

**FRONT**

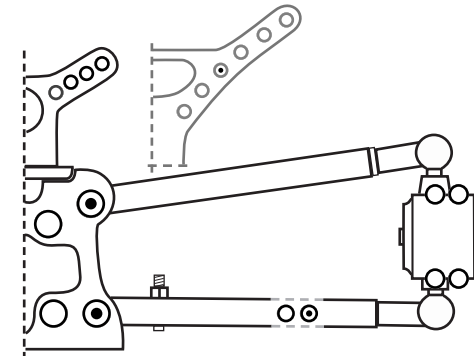

CAMBER 1 °  
 WHEEL HUBS  
 ALU  STEEL  
 WIDE  MEDIUM  NARR.  
 DROOP 66 MM  
 RIDE HEIGHT 36 MM

**ACKERMANN**

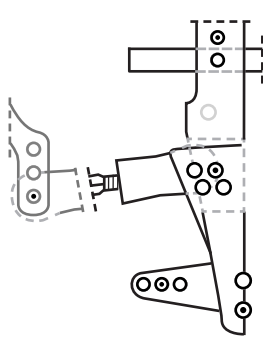
TOE 0 °  

**CASTER**

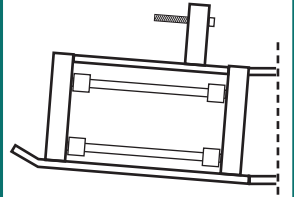

TOP  
     
 BOTTOM

**REAR**

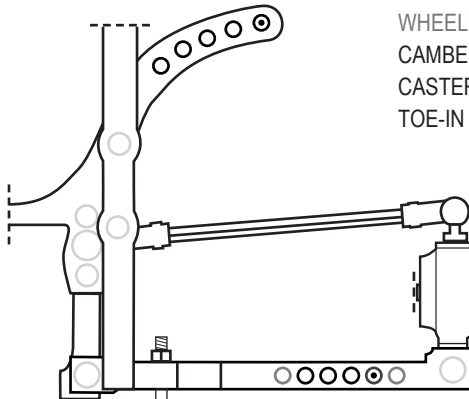

WHEELBASE  LONG  MED.  SHORT  
 CAMBER 0.5 °  
 CASTER  0°  4°  
 TOE-IN  2°  4°  
 WHEEL HUBS  
 ALU  STEEL  
 WIDE  MEDIUM  NARR.  
 DROOP 70 MM  
 RIDE HEIGHT 40 MM

**FRONT**

SHORT  
 LONG  
3 HOLES  
 \_\_\_ MM  
long  
2000  
1.9  
5 MM

CAPS  
 PISTON  
 BODY  
 OIL  
 SPRING  
 PRELOAD

**REAR**

SHORT  
 LONG  
3 HOLES  
 \_\_\_ MM  
long  
2000  
1.8  
15 MM



COMMENT  
TK08 shock used in the rear

**DRIVETRAIN**

ENGINE NAME M. Hesse Tuning SIZE 23 CCM  
 MUFLER NAME Mielke  
 CLUTCH NAME Stock AT 6000 U/MIN  
 GEARBOX SPUR GEAR 45Z PINION 19Z  
 DIFF. GEAR 48Z DIFF. PINION 16Z

**CHASSIS**

STIFFENERS  LONG  SHORT  
 FUEL TANK POSITION  LEFT  RIGHT  
 BATTERY POSITION left to fuel tank

**TRACK**

SMOOTH  SANDY  
 BUMPY  SOFT DIRT  
 LOW TRACTION  GRASS  
 MED. TRACTION  BLUE GROOVE  
 HIGH TRACTION  CLAY  
 WET  CARPET  
 DRY  OTHER

**WING**

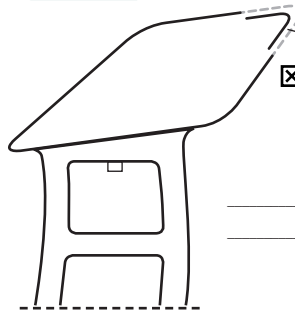

LIP  
 YES  NO  
 COMMENT  
 \_\_\_\_\_  
 \_\_\_\_\_

**BRAKES**

CENTRAL REAR BRAKE   
 CABLE DISK BRAKES   
 HYDRAULIC DISC BRAKES   
 VORNE  HINTEN  
 BRAKE NAME Mecattech  
 BRAKE DISCS Epoxi  
 HYDRAULIC OIL Motorex  
 BRAKE LOAD  
 FRONT 60% REAR 40%